

FRONT UNDER SPOILER

IMPREZA

Genuine part number E2410FE200##

Applied models: IMPREZA sedan

Components

No	Part name	Quantity
①	Front under spoiler CTR	1
②	Front under spoiler Corner LH	1
③	Front under spoiler Corner RH	1
④	Parts kit	1
a	Bolt M6	9
b	J nut spring M6	9
c	Grommet	2
d	Clip	2
⑤	Instruction manual	1
⑥	Paper template	1

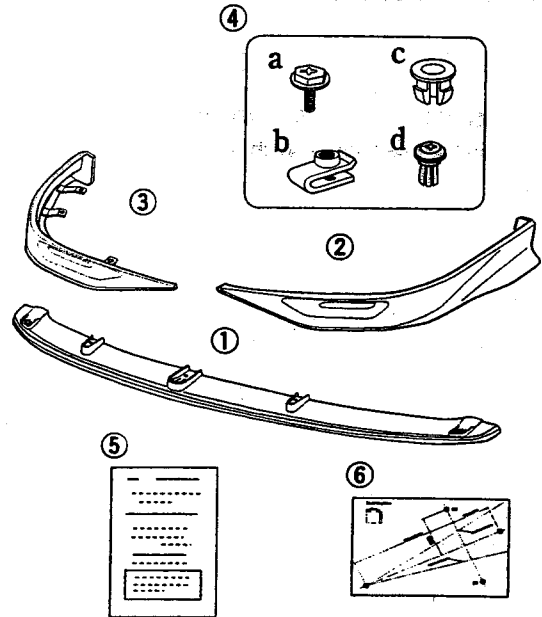

NOTE: A paper template ⑥ is enclosed with the kit.
For high volume (dealer) installations, a plastic template E2418FE005 is available.

Tools to use

Courtesy: SubaruParts.com Toll-Free 877-473-6200

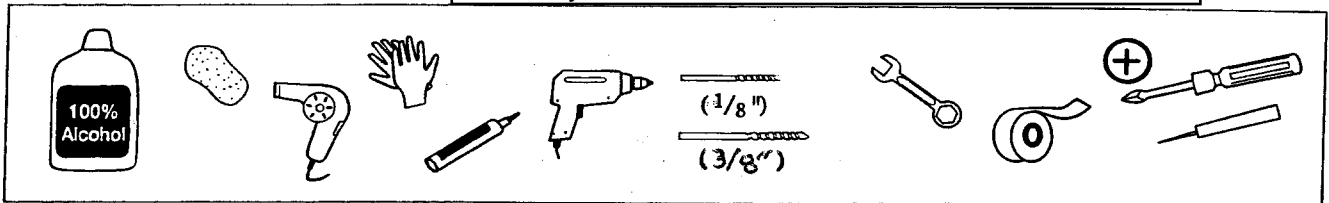

Installation drawing

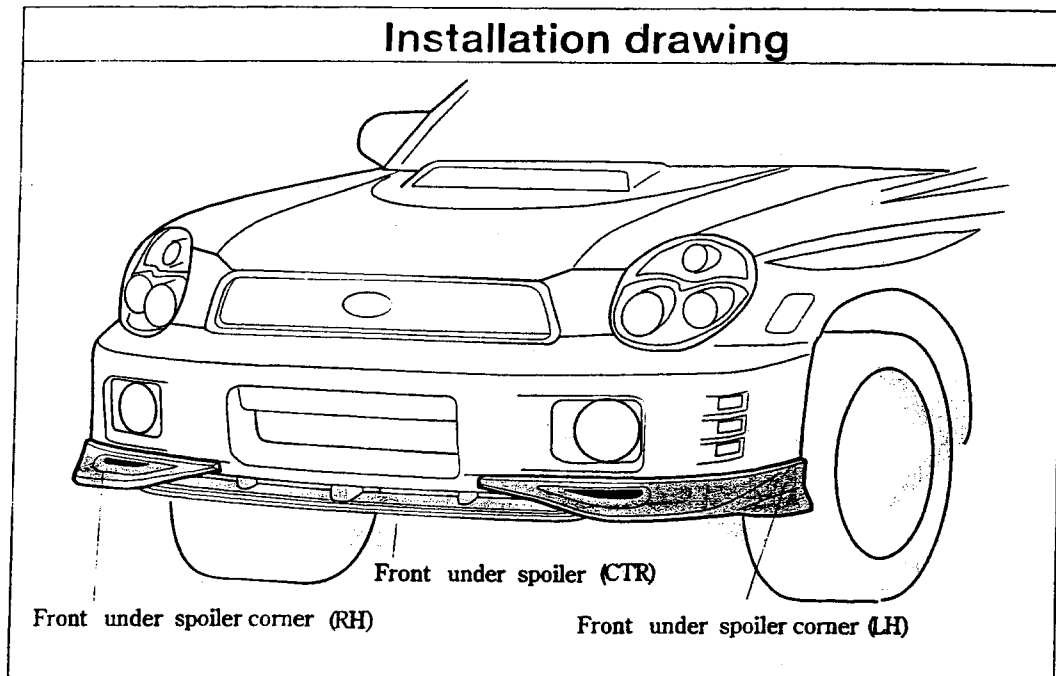

Installation procedures

1

2

(2x)

3 **LH**

1 ↑

2

E2418FE005

Using the attached paper template

LH

8

4 **LH**

1

2

(1/8")

(3/8")

drill stop

5 **LH**

3

4

dispose of tape backing

25°C ~ 40°C

15°C

6 LH

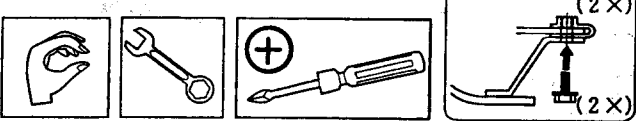
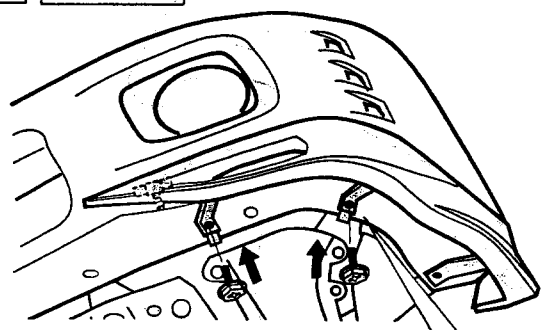

7 LH

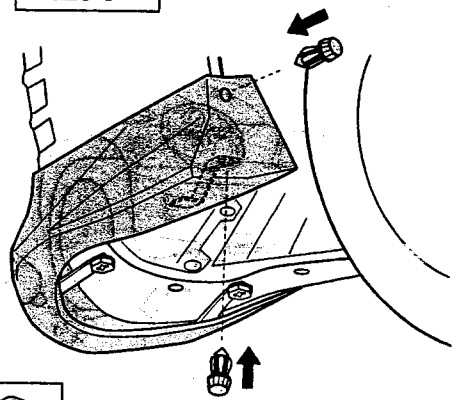

8 RH

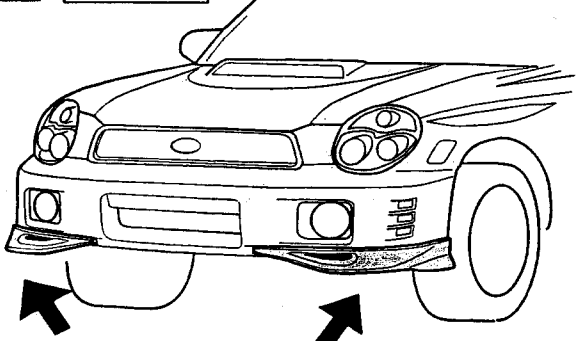

RH
3 ~ 7

LH
3 ~ 7

9

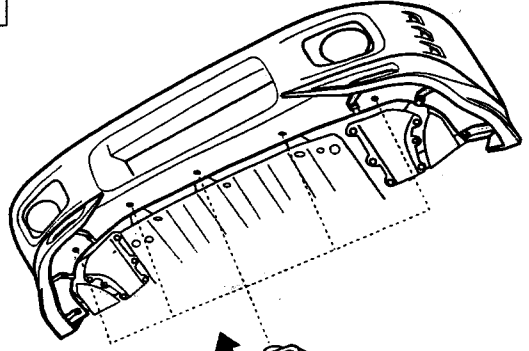

10

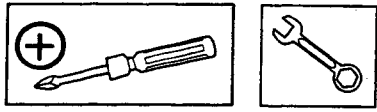
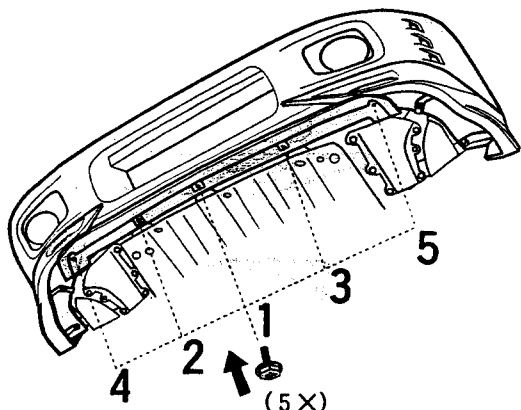

Check after installation

1. Check whether the front under spoiler is installed securely with mounting clips.

FRONT UNDER SPOILER

IMPREZA

PAPER MARKING TEMPLATE

The paper template (see other side) is for one time use only.
Do not copy. For high volume (dealer) installations, a plastic
template E2418FE005 is available.

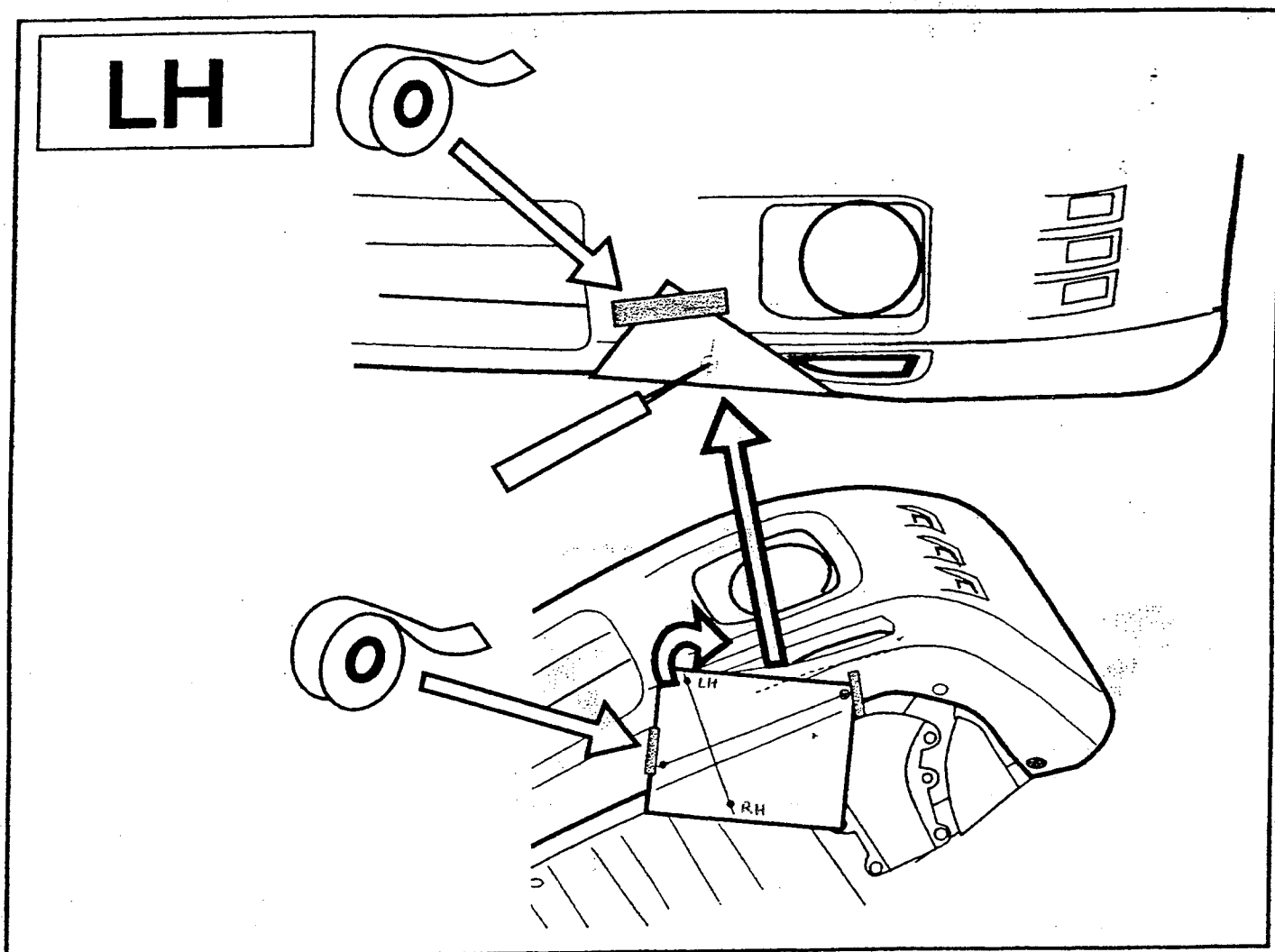

Paper template

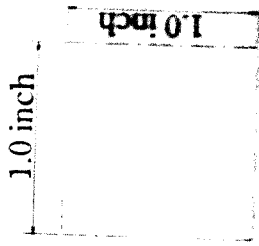

NOTE: If The Paper Template Is Not To Scale, Enlarge As Required

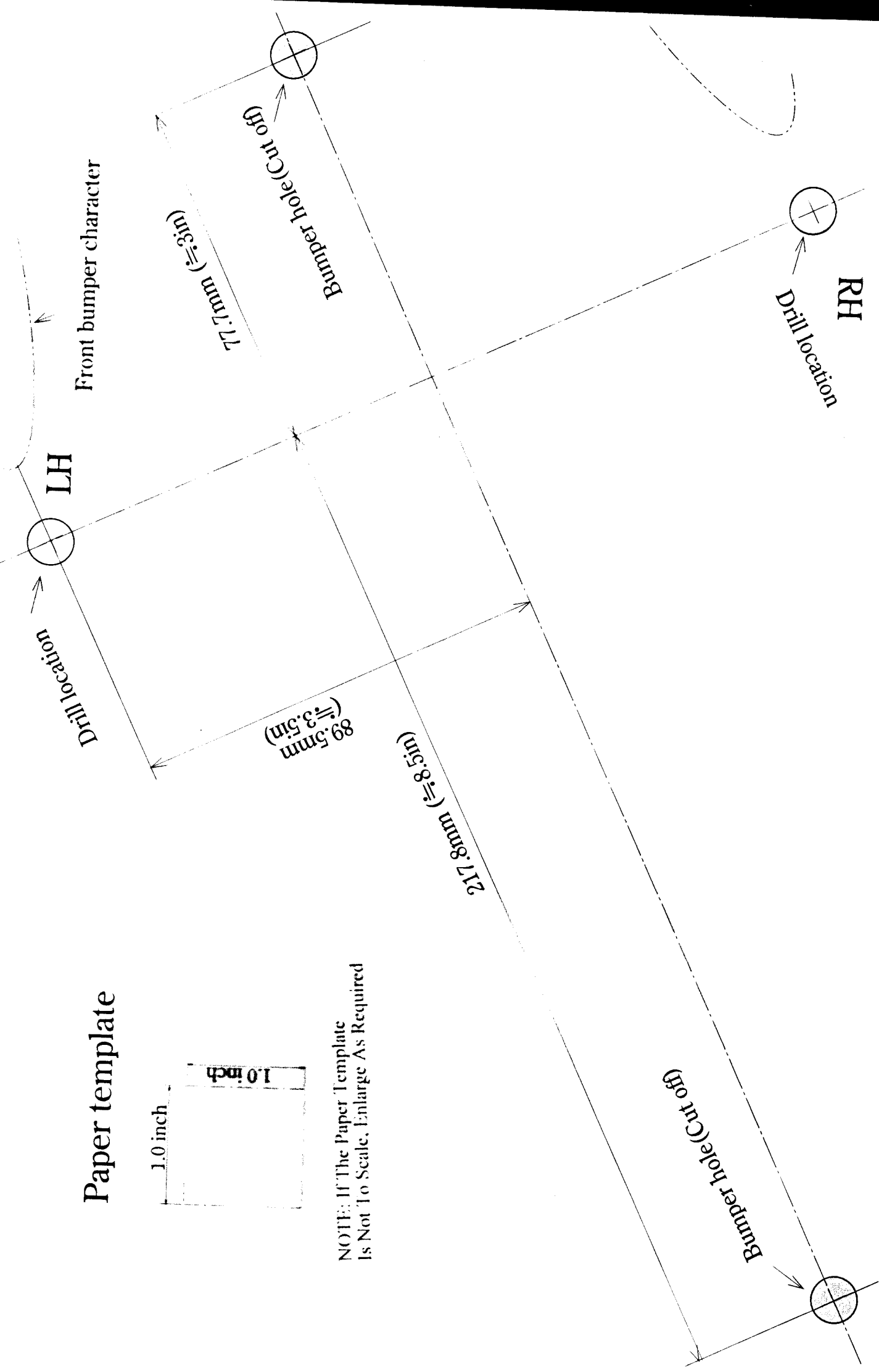

Front Under Spoiler - Installation Instruction Text

Step 1:

Remove all dust, dirt, road salt, etc. from all mating surfaces.

Step 2:

Remove existing fasteners from the wheel well area of the bumper fascia using a Phillips (+) screw driver and discard (as shown in step 2, small sketch). Remove the existing fasteners from the underside of the bumper fascia and retain for re-installation.

Step 3:

Utilizing the Plastic Marking template (E2418FE005), mark the drill locations (one location each side) using a punch. You can not proceed with this installation unless you have the Plastic Marking template (E2418FE005).

Step 4:

Utilizing a 1/8" drill bit, drill the pilot holes (two locations) as noted in Step 3. Then enlarge the hole using a 3/8" drill bit. Insert a plastic grommet (two locations) into the 3/8" holes. (Note: Be sure to use a 3/8" drill stop)

Step 5:

Note: Before proceeding, insure that all dust, dirt, road salt, has been removed from all mating surfaces and that all components are at room temperature (60F to 100F). Remove the red tape backing liner and discard. Locate the Front Under Spoiler side component on the vehicle fascia and align the male locking pin with the plastic clip. Firmly insert the pin into the grommet and press (and hold) the area with the double sided tape for 15 seconds, to insure adhesion.

Step 6:

Insert two "J nuts" (4 locations total) onto the underside of the vehicle's bumper (as shown in step 6, small sketch) and use a wrench to secure two "M6 bolts" (4 locations total) through the Front Under Spoiler side component and into the "J nuts".

Step 7:

Re-install the fasteners removed in step 2. Insert the clip provided with this kit into the wheel well area of the bumper fascia.

Step 8:

Step 3 through Step 7 must be repeated for both driver's and passenger's sides.

Step 9:

Insert five "J nuts" onto the underside of the vehicle's bumper fascia (as shown in step 9).

Step 10:

Locate the Front Under Spoiler center section on the bumper fascia. Then use a wrench to secure five (5) "M6 bolts" through the Front Under Spoiler center section, through the bumper fascia, and into the "J nuts".