

SUBARU

INSTALLATION
INSTRUCTIONS

CROSSBAR KIT FOR IMPREZA WAGON ROOF RAILS E3610SS000

CONTENTS:

- (2) Crossbar Assemblies
 - (1) Front Crossbar (E3610SS010)
 - (1) Rear Crossbar (E3610SS020)
- (1) T-30 Torx Head Wrench (#E3610AS730)
- (1) Installation Instructions

PLEASE READ ENTIRE TEXT BEFORE STARTING INSTALLATION

- 1). Obtain the **Rear Crossbar** and the T-30 Torx head wrench from the carton.
- 2). Loosen and remove the T-30 Torx head screw from the top of each crossbar end support (see *Figure 2*) and return for later use. Rotate the lower clamp on the bottom of each end support downward approximately 90°.
- 3). With the front direction arrow label on the top right side of the crossbar assy. pointing toward the front of the vehicle, carefully place the crossbar assy. across the top of the vehicle so that the crossbar end supports rest on the top of the roof rails.
- 4). Position the rear of the crossbar end support, even with the seam (*joint*) between the rear roof rail support and the rail.
- 5). Rotate (*raise*) the lower clamp up to the bottom of the roof rail and loose assemble the T-30 Torx head screw, with the wrench provided, through the top of the end support and into the threaded insert in the lower clamp on each end of the crossbar assy. Adjust the alignment of the crossbar assy. on the roof rails, and if available, use a T-30 Torx bit & torque wrench and tighten the T-30 Torx head screws to 30-35 inch lbs. (3.4-4.0 newton meters) of torque (*or tighten securely with the torx wrench provided*).

NOTE: *It may be necessary to squeeze the lower clamp and the end support together to compress the pads and gain a better alignment of the pieces while trying to start the screw. Use care not to crossthread the screw in the insert.*

- 6). Obtain the **Front Crossbar** from carton.
- 7). Repeat procedures 2-5.

NOTE: *The front edge of the front crossbar support should be located approximately three (3") inches rearward of the seam (joint) between the front roof rail support and the roof rail.*

- 8). Place the **T-30 Torx Tool** (#E3610AS730) and this **Instruction Sheet** in the vehicle glove box.
- 9). Care & Cleaning of this product should be the same as the vehicles exterior painted surfaces and trim described in the Owners Manual.

NOTE: *Before each use of the roof rack, make sure the four (4) T-30 crossbar clamp screws have been checked, and retightened if necessary to 35 inch lbs., as outlined in Step #6 above.*

NOTE: *Loosen T30 Torx Head Screws and totally dislodge the Crossbar End Supports from Roof Rails prior to any movement of Crossbar Assemblies.*

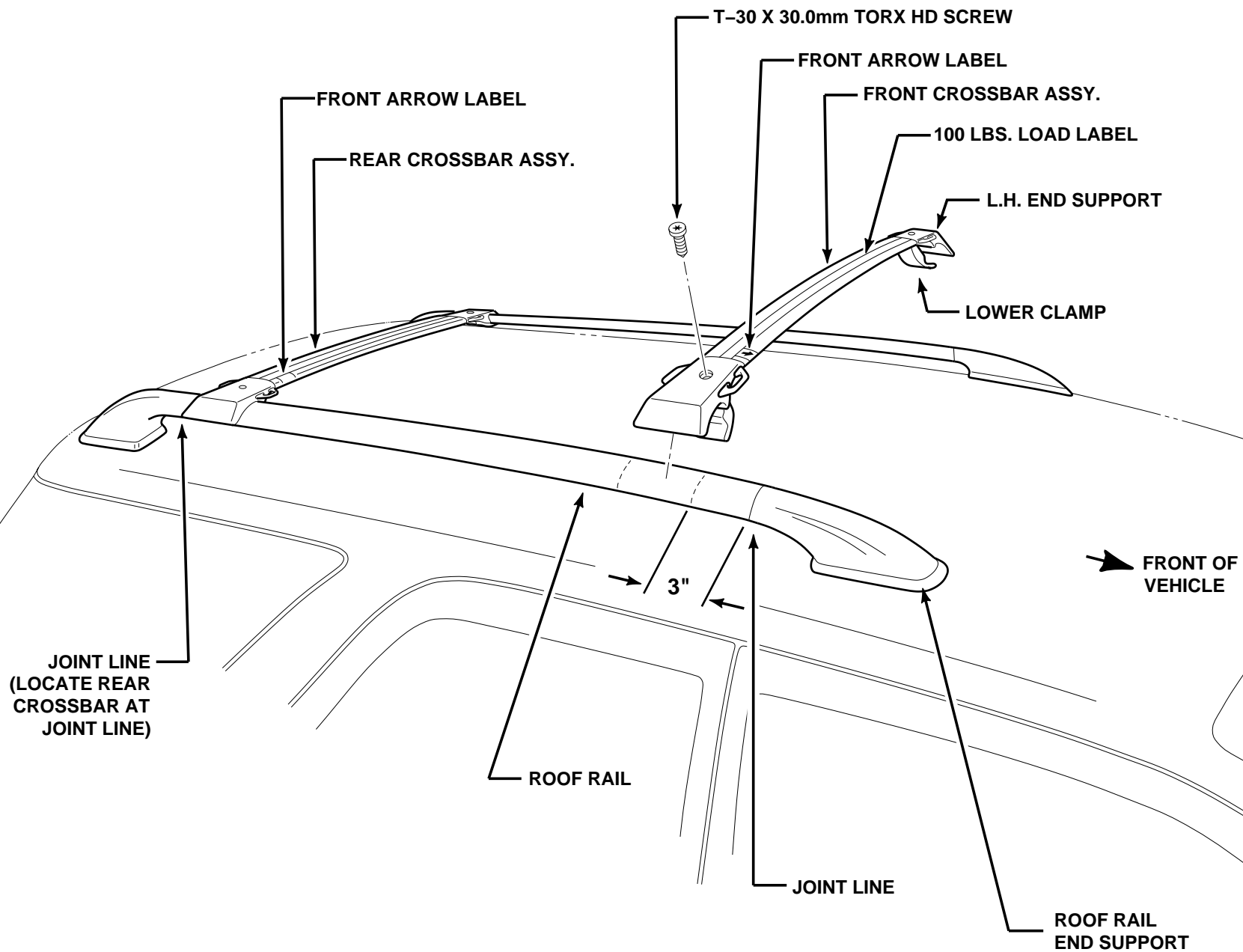

FIGURE A
CROSSBAR ASSEMBLY
INSTALLATION